





Panoramic Frame

Component - Pano_Wall_10_B

Frame Assembly

Parts -	total # of pieces	Pano_L-Frame	Pano_I-Frame	Pano_T-Frame	Pano_F-Frame Horizontals
Pano_L-Frame	2				
Pano_I-Frame	2				
Pano_T-Frame	2				
Pano_F-Frame - Top	6				
Pano_F-Frame - Bottom	6				

W:115.75" D:17.3" H:94.5"

Note: Frame connection points are labeled with letters.
Graphic installation points are identified with numbers.

Step 1 - Arrange bottom Pano_F horizontal sections in place according to frame detail. Corner connectors will already be in place and sections will be labeled with a single letter at each end.

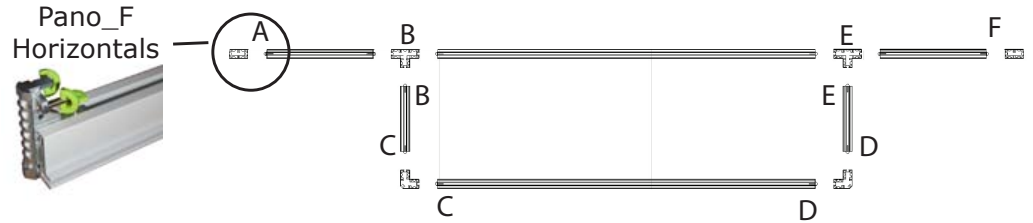

Step 2 - Place assembled vertical posts down onto corner connector on horizontal section. Do one wall or section at a time. Tighten D screws on vertical posts.

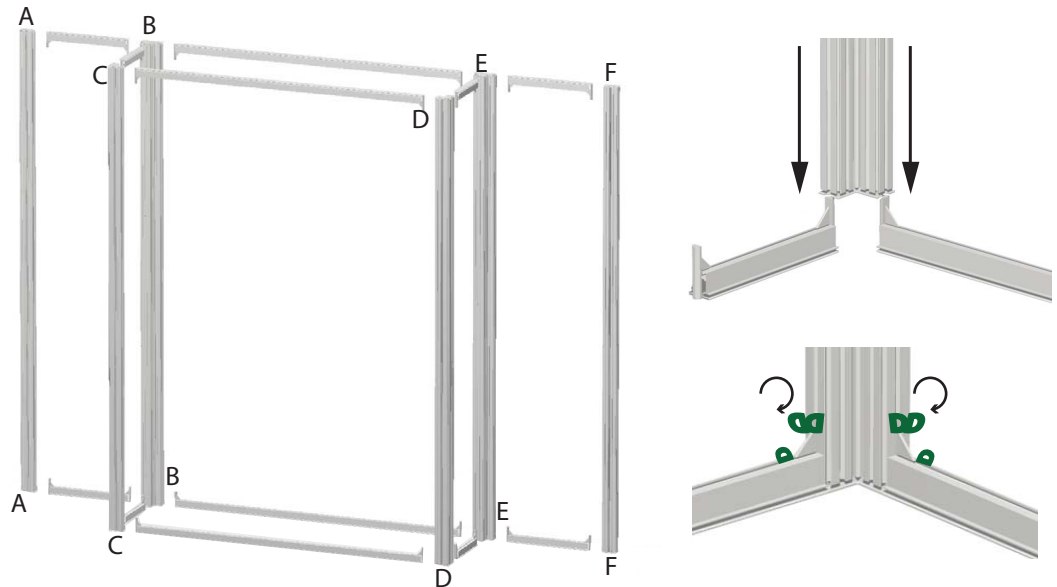

Step 3 - Top horizontal posts will have the same labels as the bottom horizontals with corner connectors attached. Slide top extrusion connectors down onto tops of vertical posts. Tighten D screws on vertical posts.

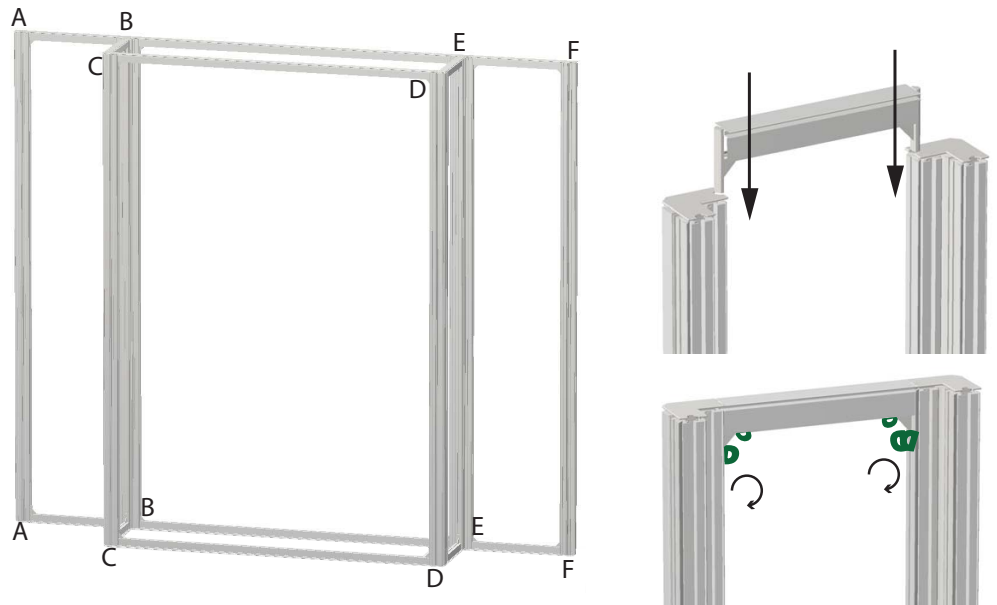

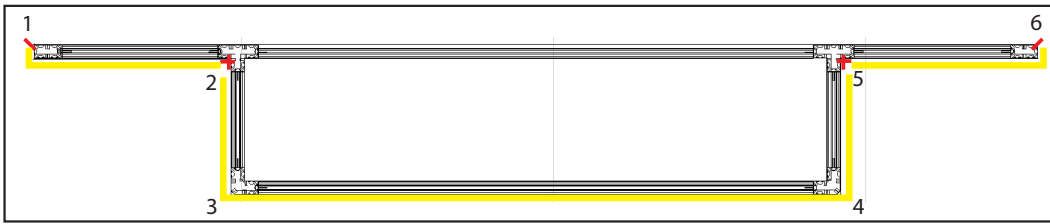

Note: Frame connection points are labeled with letters.
Graphic installation points are identified with numbers.

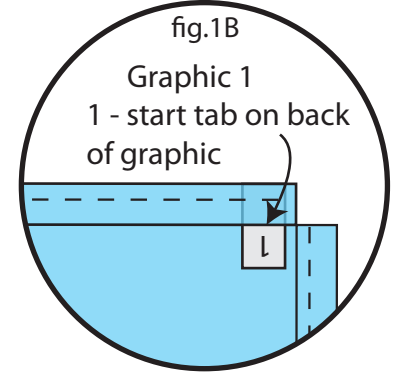
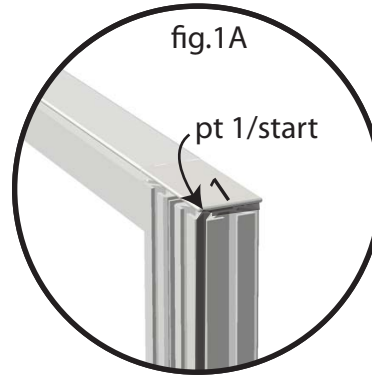
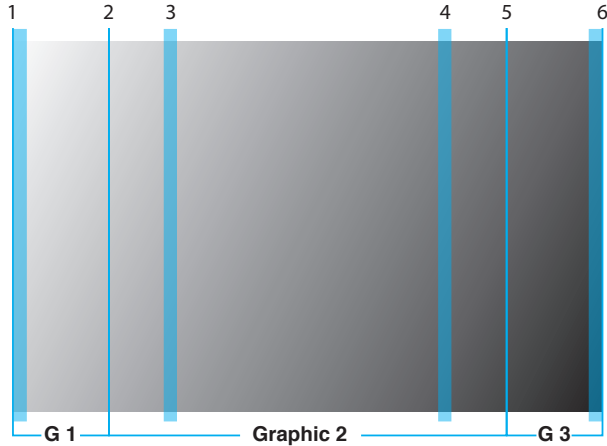

Step 1 - Identify start point on top of frame (fig. 1A, label - 1) and graphic top left corner (fig. 1B, shown in blue).

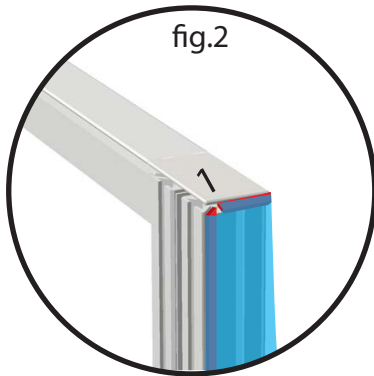

Step 2 - Insert 1 Top corner of graphic and welt into top groove of L vertical post at point 1. Align welt on left with vertical groove, insert a few inches. See fig. 2

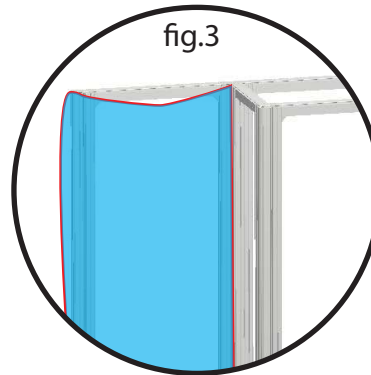

Step 3 - Align corner 2 of graphic with corner 2 on frame. Continue aligning corners around frame to final stop point.

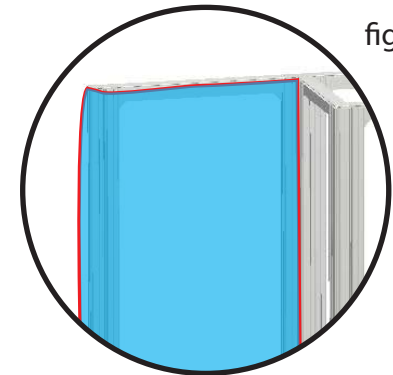

Step 4 - Work in top welt between corners from center out to corners making sure graphic is evenly distributed.

Be sure to push graphic into the groove, not slide.

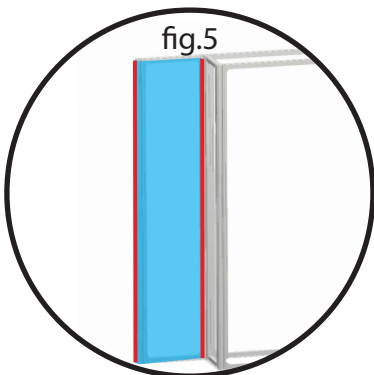

Step 5 - Insert welt in vertical grooves between top and bottom corners. Work from middle out making sure graphic is evenly distributed.

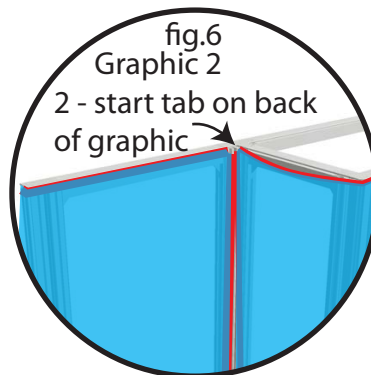

Step 6 - For frames with multiple graphics, align next graphic with first. Follow steps 1-5 before doing bottom.

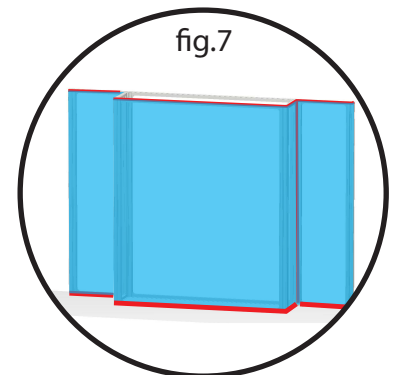

Step 7 - Follow steps 1-5 for bottom of graphic.